

SCT SERIES- SPOT / CENTERING TOOL

- Manual Mills or CNC Spotting, Centering, Slotting
- Manual Lathe or CNC Centering, Facing, Grooving, OD, ID Chamfer
- Unique design to produce a multitude of applications

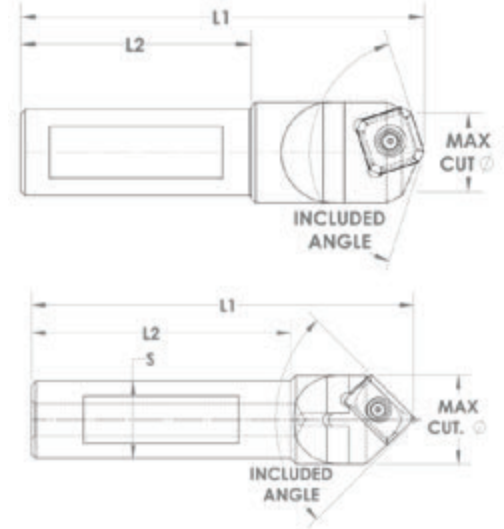

Straight Shank - Coolant Style

Part #	EDP#	Tool Description and Included Angle	(L1)	(L2)	Max Cut Dia.	(S)	Insert Description	Screws
SCT0490-0375-2250	V8122	82° - 1/4" IC Insert	2.25"	1.50"	Ø.49	.375"	XEGW 21.5X	F1109
SCT0520-0375-2250	V8120	90° - 1/4" IC insert	2.25"	1.50"	Ø.52	.375"	XEGW 21.5X	F1109
SCT0860-0750-3700	V8000	90° - 3/8" IC Insert	3.70"	2.50"	Ø.86	.750"	XEGW 32X	F575
SCT0860-0750-3700X	V8620	90° - V8000 w/ no flat	3.70"	2.50"	Ø.86	.750"	XEGW 32X	F575
SCT0560-0375-2250	V9150	100° - 1/4" IC insert	2.25"	1.50"	Ø.56	.375"	XEGW 21.5X	F1109
SCT1030-0750-3700	V8172	120° - 3/8" IC Insert	3.70"	2.50"	Ø1.03	.750"	XEGW 32X	F575
SCT0700-0750-3750	V1361	144° - 1/2" IC Insert	3.75"	2.00"	Ø.70	.750"	SXEX 42A	F610

Hardware for SPOT & Centering Tools

INSERT	SCREW
XEGW 21.5X	F1109
XEGW 32	F575
SXEX 42A	F610