

ACM SERIES—ANGLE & CHAMFER MILL

- 45° Chamfering—Top and/or Bottom, Back and/or Front, Angle Roughing, Face Milling, Slotting, etc.
- Positive Shear design for lessening tool pressures in all cutting applications

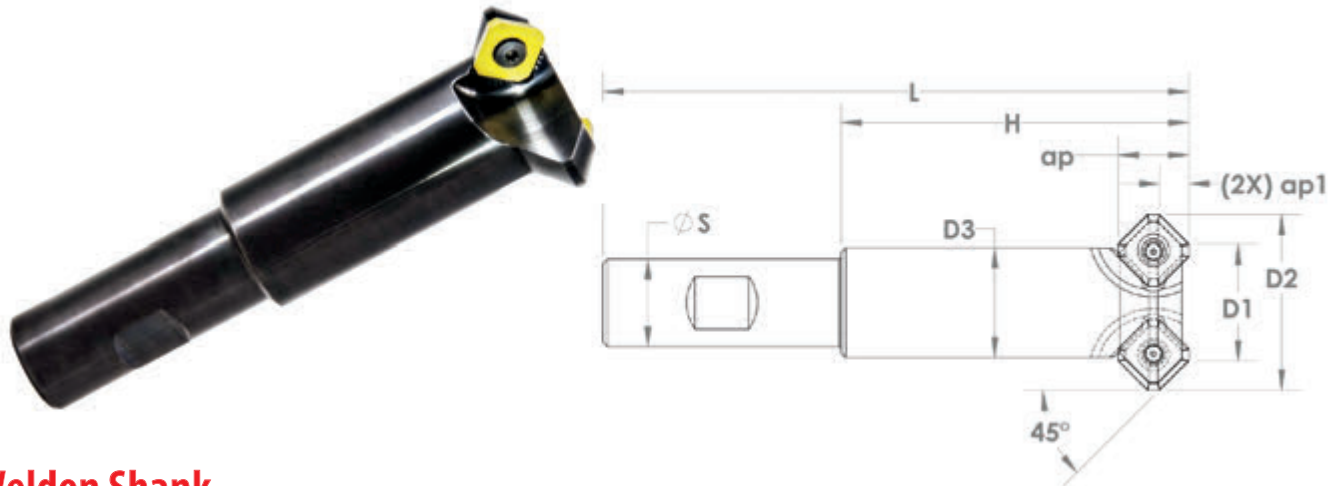

Weldon Shank

Part #	EDP#	(D1)	(D2)	(D3)	(ap)	(ap1)	(S)	(L)	(H)	Insert	Qty. of Inserts
ACM1500-0750-50002	V12050	1.000"	1.500"	.938"	.60"	.25	.750"	5.00"	2.97"	SXEX 42A	2
ACM2000-1000-60003	V12051	1.500"	2.000"	1.438"	.60"	.25	1.000"	6.00"	3.72"	SXEX 42A	3
ACM2500-1250-70003	V12052	2.000"	2.500"	1.938"	.60"	.25	1.250"	7.00"	4.72"	SXEX 42A	3

Shell Mill Mount

Part #	EDP#	(D1)	(D2)	(D3)	(ap)	(ap1)	(L)	Pilot Dia.	Insert	Qty. of Inserts
ACM2500-0750-17504SM	V12053	2.000"	2.500"	1.900"	.60"	.25	1.75"	.750"	SXEX 42A	4
ACM3000-0750-20004SM	V12054	2.500"	3.000"	1.900"	.60"	.25	2.00"	.750"	SXEX 42A	4
ACM4000-1000-22505SM	V12055	3.500"	4.000"	2.400"	.60"	.25	2.25"	1.000"	SXEX 42A	5
ACM5000-1000-22505SM	V12056	4.500"	5.000"	2.400"	.60"	.25	2.25"	1.000"	SXEX 42A	5
ACM6000-1250-22506SM	V12057	5.500"	6.000"	2.900"	.60"	.25	2.25"	1.250"	SXEX 42A	6

Hardware for Angle & Chamfer Mill

INSERT	SCREW
SXEX 42A	F610